

REV.	ECN - DESCRIP.	DATE	DRWN.	CHKD.	APP.
02	1169	10/7/93	M.B.	R.S.	B.A.
03	2292	3/28/03			

Choice of Neck Ring Threads

- 3 1/8-11 UNS Thd.
- 3 1/8-7 UNS Thd.
- 3.147-11 UNS Thd.

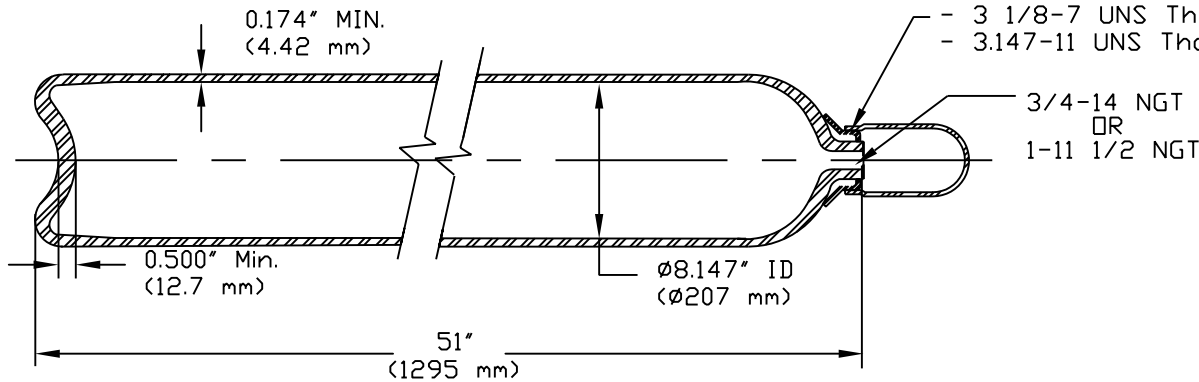

DRAWING FOR REFERENCE ONLY

SPECIFICATION: DOT 3AA 2015/TC3AAM154

MODEL: 8BC200/TC

1. Principal Elements: - Min. water capacity: 86.3 lbs (39.1 kg) - Min. water volume: 2395 in ³ (39.1 liter) - Approx. tareweight: 101 lbs (45.8 kg) - DOT Service pressure: 2015psi (138.9 bar) - TC Service pressure: 154 bar - Test pressure: 3360psi (231.7 bar)	3. Manufacture: Hot billet pierce followed by hot drawing.
	4. Heat Treatment: Q & T
2. Material: Chrome-Moly steel, (A.I.S.I. 4130X)	5. Norris Standard Mechanical Properties: - Tensile: ≥ 105,000 psi (724 MPa) - Elong: ≥ 20% (on 2" gauge) - Flattening: to 6xt without cracks

D.O.T. Wall Stress Calculations: $S = P(1.3D^2 + 0.4d^2)/(D^2 - d^2)$

$$S = \text{Maximum wall stress, psi} \quad S = \frac{3360 [1.3 (8.495)^2 + 0.4 (8.147)^2]}{(8.495)^2 - (8.147)^2}$$

P = Test pressure, psi

D = Outside diameter, inch

d = Inside diameter, inch

$$S = 69,832 \text{ psi (481.5 MPa)}$$

$$\text{Required Minimum Tensile:} = \frac{69,832}{0.67} = 104,227 \text{ psi (718.6 MPa)}$$



NORRIS CYLINDER COMPANY

P.O. BOX 7486 LONGVIEW, TEXAS 75607

SEAMLESS STEEL CARBON DIOXIDE CYLINDER, MODEL 8BC200/TC

SCALE	NOT TO SCALE	DRAWING NO.	REV.
DWN. BY	S. JOHNSON	10/31/91	03
CHK'D BY	R. SHAFKEY	11/28/91	
APP'D BY	B. ARNOLD	12/3/91	
		SHEET NO. 1	OF 1 SHEETS